



**LG**

North/Latin America  
Europe/Africa  
Asia/Oceania

<http://aic.lgservice.com>  
<http://eic.lgservice.com>  
<http://biz.lgservice.com>

# PLASMA TV

## SCHEMATICS and EXPLODED VIEW

CHASSIS : PU14K

**MODEL : 50PV400/430/450**

**50PV400-UB/50PV430-UC/**

**50PV450-UA/**

### CAUTION

BEFORE SERVICING THE CHASSIS,  
READ THE SAFETY PRECAUTIONS IN THIS MANUAL.

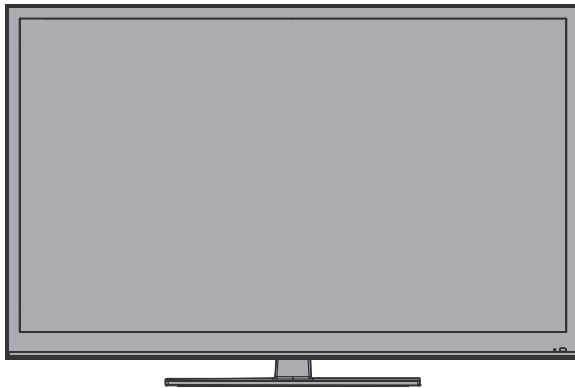

# EXPLODED VIEW

## IMPORTANT SAFETY NOTICE

Many electrical and mechanical parts in this chassis have special safety-related characteristics. These parts are identified by  $\Delta$  in the Schematic Diagram and EXPLODED VIEW. It is essential that these special safety parts should be replaced with the same components as recommended in this manual to prevent X-RADIATION, Shock, Fire, or other Hazards. Do not modify the original design without permission of manufacturer.

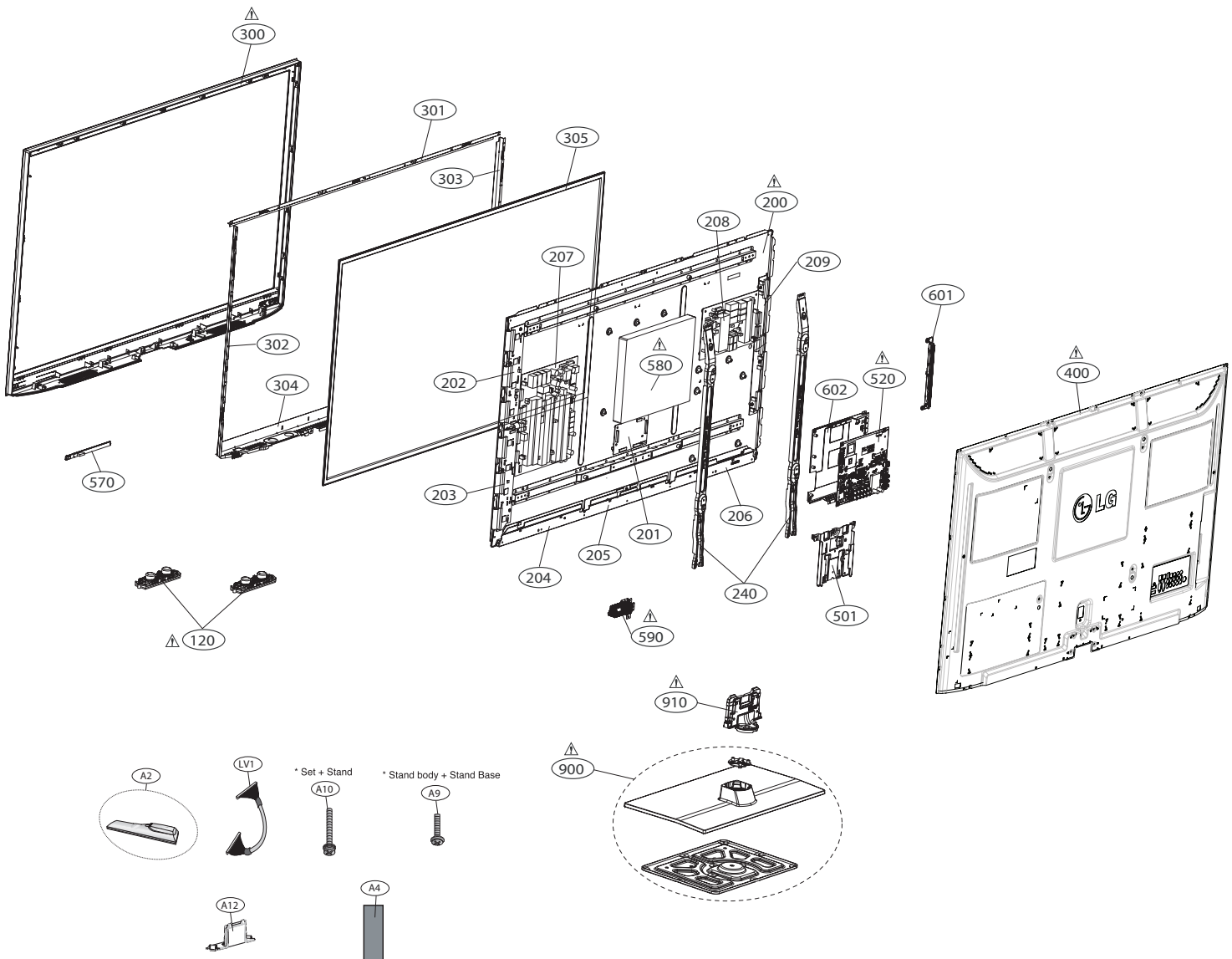

EXPLODED	PART NO.	DESCRIPTION	SPECIFICATION
120	EAB62028901	Speaker,Full Range	G153 ND 10W 8OHM 80DB 120HZ 150x35x22 CONNECTOR EMSONIC CORPORATION
200	EAJ61527904	PDP,Module-FullHD	PDP50R30000.ASLGB FULLHD 50INCH 1920X1080 16/9 LG ELECTRONICS INC.
200	EAJ61527931	50 Inch_FHD PDP Module	PDP50R30000.ASLGM FULLHD 50INCH 1920X1080 16/9 LG ELECTRONICS INC.
201	EBR71727801	Hand Insert PCB Assembly	CTRL ASS'Y HAND INSERT 50" R3 CTRL
202	EBR69839101	Hand Insert PCB Assembly	YDRV ASS'Y HAND INSERT 50" R3 YDRV TOP
203	EBR69839201	Hand Insert PCB Assembly	YDRV ASS'Y HAND INSERT 50" R3 YDRV BTM
204	EBR71728101	Hand Insert PCB Assembly	XRLB ASSY HAND INSERT 50" R3 XL
205	EBR71728401	Hand Insert PCB Assembly	XRCB ASSY HAND INSERT 50" R3 XC
206	EBR71728501	Hand Insert PCB Assembly	XRRB ASSY HAND INSERT 50" R3 XR
208	EBR71727901	Hand Insert PCB Assembly	ZSUS ASS'Y HAND INSERT 50" R3 ZSUS
240	MJH62356101	Supporter	PRESS EGI 1.2 Supporter EGI 50PW2/3/4/5/7/9 Supp.Vertical LGERS Local
300	ABJ73308805	Cabinet Assembly	50PV450-UA NON 50" 50PV450-UA CABINET ASSY C/SKD
301	AJJ73198506	Supporter Assembly	50PV/Z250/350/550 Supp.filter Top Assy(FHD Model_R3 Module) RS Local Phantom
302	AJJ73198712	Supporter Assembly	50PZ/V250/350/550 Supp.filter Side L Assy(FHD_R3 Model)LGERS Local Phantom
303	AJJ73198711	Supporter Assembly	50PZ/V250/350/550 Supp.filter Side R Assy(FHD_R3 Model)LGERS Local Phantom
304	AJJ73198606	Supporter Assembly	50PZ/V250/350/550 Supp.filter Bot Assy(FHD_R3 Module) LGERS Local Phantom
305	MDJ62166802	Filter	CUTTING GLASS GLASS FILTER 50PK(3/5) P-mesh BC AR-less FHD LGC
305	MDJ62166804	Filter	CUTTING GLASS GLASS FILTER 50PK(3/5) Cu-mesh BC AR-less FHD LGC
305	MDJ63005404	Filter	CUTTING GLASS GLASS FILTER 50PV&PZ20/30/40//50 MOG BC AR-less HD 2D&3D SKC-Haas
400	ACQ83110327	Cover Assembly,Rear	50PT350-UD NON 50" 50PT350-UD Startrek RR ASSY BACK COVER LGERS Local Phantom
501	MJH62195202	Supporter	PRESS EGI 1.2 Supporter EGI 50PW2/3/4/5/7/9 Stand Guide SKD
520	EBT61397427	DMS Chassis Assembly	MAIN PU14K 50PV450-UA Main assy total (USA, CKD)
520	EBT61397430	DMS Chassis Assembly	MAIN PU14K 60PV450-UA Main assy total (USA, CKD)
520	EBR68293414	DMS Chassis Assembly	MAIN M.J PU14K 50/60PV450 KCCLLJR/KUSLLJR/KWMLLJR Statrek-RR Main assy (CKD)
520	EBR72942909	DMS Chassis Assembly	MAIN PAKING PU14K 50/60PV450-UA SCCLLJR/SUSLLJR/SWMLLJR SKD package Assy
520	EBU60952917	BPR Total Assembly	MAIN 50/60PV450-UA LG PU14K BPR T.T
570	EBR72650101	PCB Assembly,Sub	PZ550-ZA IR/Touch Assy.
580	EAY62171101	SMPS,AC/DC	100V-240V 400W 50 To 60 Hz
590	EAM62090703	Filter,AC Line	IFZ-M05ADD1 5.3mH+0.53mH+23uH 250VAC 5A 0.1uF 470pF YH396-02M(RD),500mm LEAD WIRE BK DONG IL TECHNOLOGY LTD.
601	ABA73488807	Bracket Assembly	BRACKET 11 Year PDP Model NON Side AV Bracket Small Assy GP2R ATSC N.America with SKD
602	MGJ62886302	Plate,Metal	PRESS EGI 0.6 SHIELD EGI LGERS Local Sustain Shield Small GP2R ATSC
900	AAN73430006	Base Assembly	STAND 50PW2/3/4/5 NON 50PW2/3/4/5 Stand Assy Phantom LGERS Local
910	MJH62195302	Supporter	MOLD GLASS FIBER Supporter FIBER 50PW250/350/450/550 STAND SUPPORTER(PC+GF30) SKD
A10	FAB30016424	Screw Assembly	FAB30016423 MACHINE TYPE D4.0 L26.0 WASHER1 (D:8.0 , T:0.8) , WASHER2 (D:7.0 , T:1.0),BK SEUNGBO MECHA TECH CO.,LTD
A2	AKB72914053	Remote Controller Assembly	PDP LS-Con, Startrek_RR, North America
A4	MAF60779001	Bag,Vinyl	COMPLEX ACCESORY 150*150 0.41t cloth cleaner
A9	FAB30016616	Screw Assembly	FAB30016616 MACHINE TYPE D5.0 L14.0 PLAIN WASHER(D:10, T:1.0) APPLIED NYLON SPRAY SEUNGBO MECHA TECH CO.,LTD
LV1	EAD61668702	Cable,FFC	EAD61668702 325MM 0.50MM 80P WHITE UL20861 non reverse YOUNG SHIN CO.LTD
n/a	EBR71728001	Hand Insert PCB Assembly	ZSUS SUB ASS'Y HAND INSERT 50" R3 ZSUB

IC1  
LGE4873A (SATURN 4 LITE PLUS\_NON SRS)

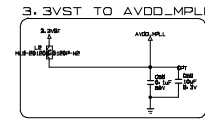
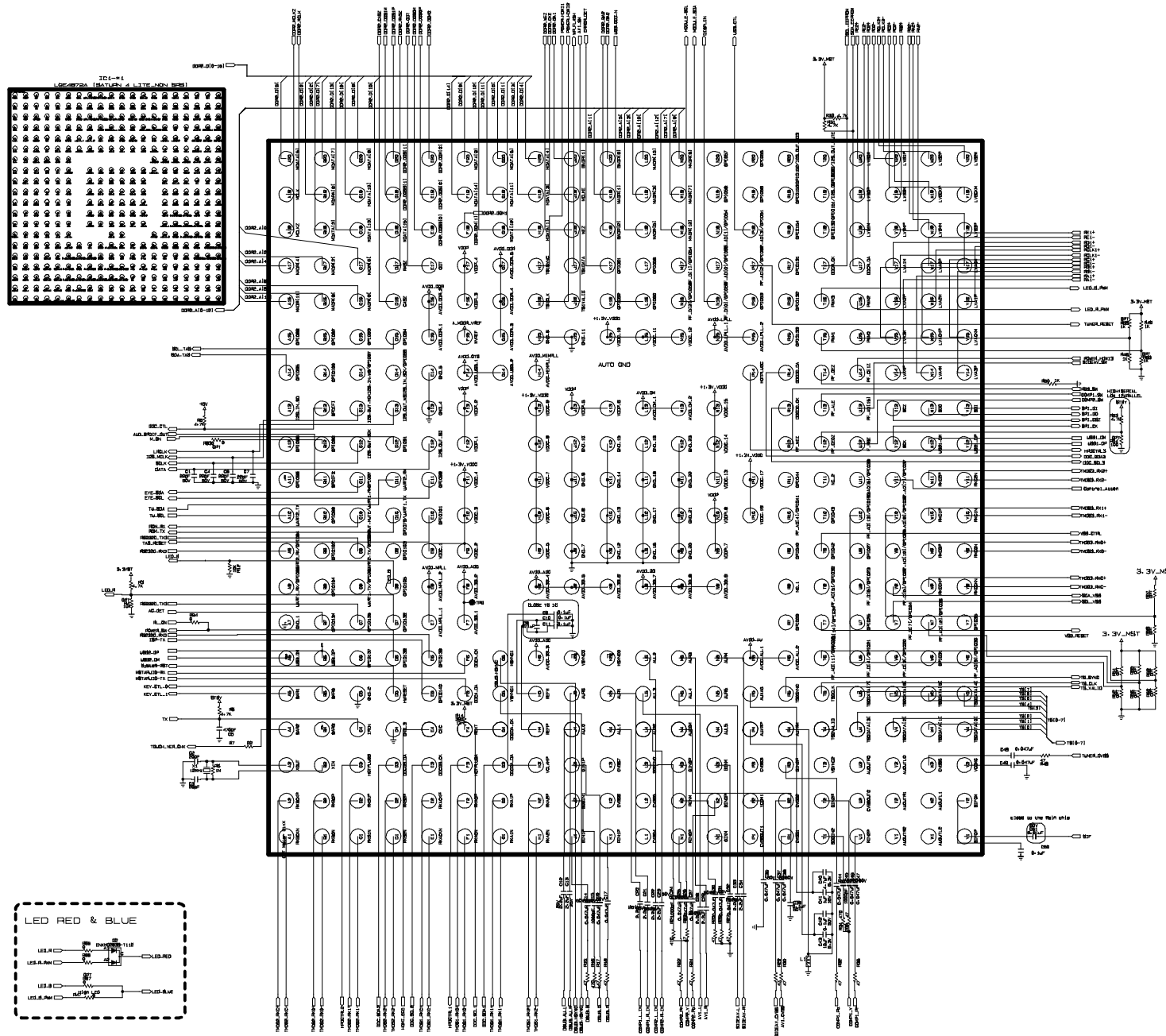

CLOSE TO IC

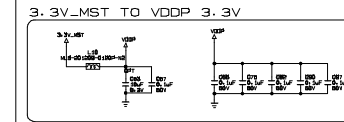

3.3V\_MST TO AVDD 3.3V

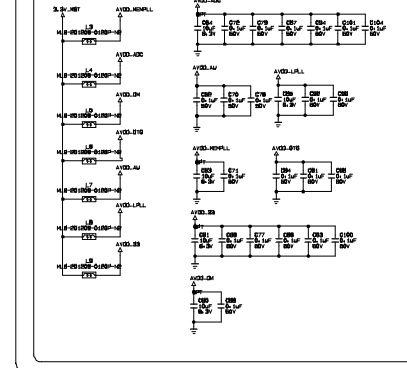

+1.3V TO VDDC

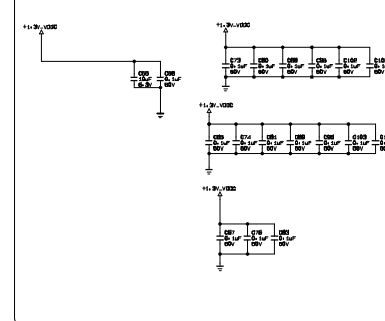

Reset

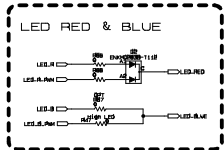
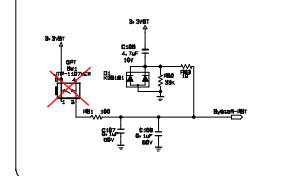

THE  $\Delta$  SYMBOL MARK OF THIS SCHEMATIC DIAGRAM INCORPORATES SPECIAL FEATURES IMPORTANT FOR PROTECTION FROM X-RADIATION. FILTRER AND ELECTRICAL SHOCK HAZARDS- WHEN SERVICING IF IS ESSENTIAL THAT ONLY MANUFACTURER SPECIFIED PARTS BE USED FOR THE CRITICAL COMPONENTS IN THE  $\Delta$  SYMBOL MARK OF THE SCHEMATIC.

SECRET  
LGElectronics



MODEL		DATE	
BLOCK		SHEET	/

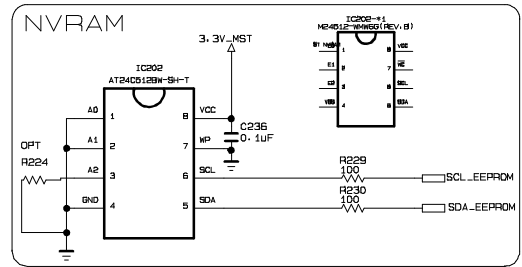
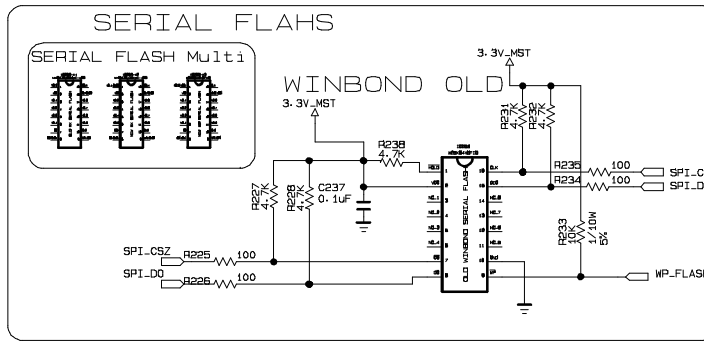
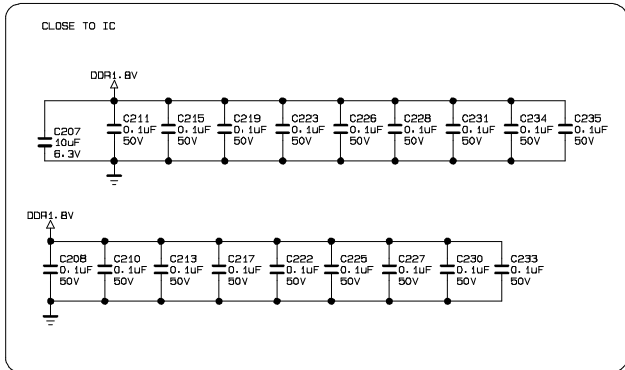
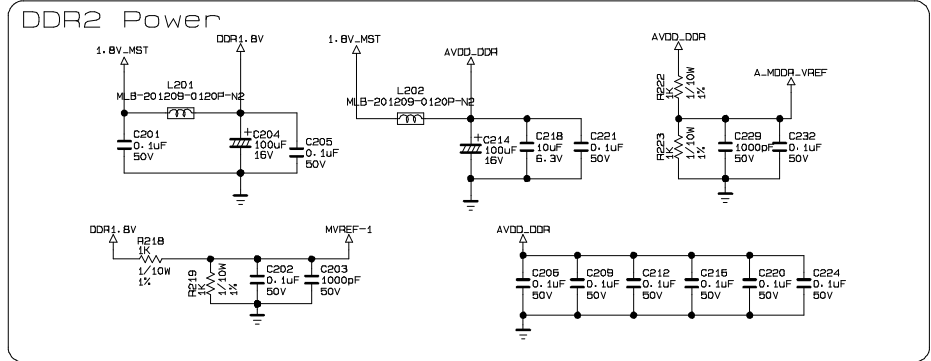
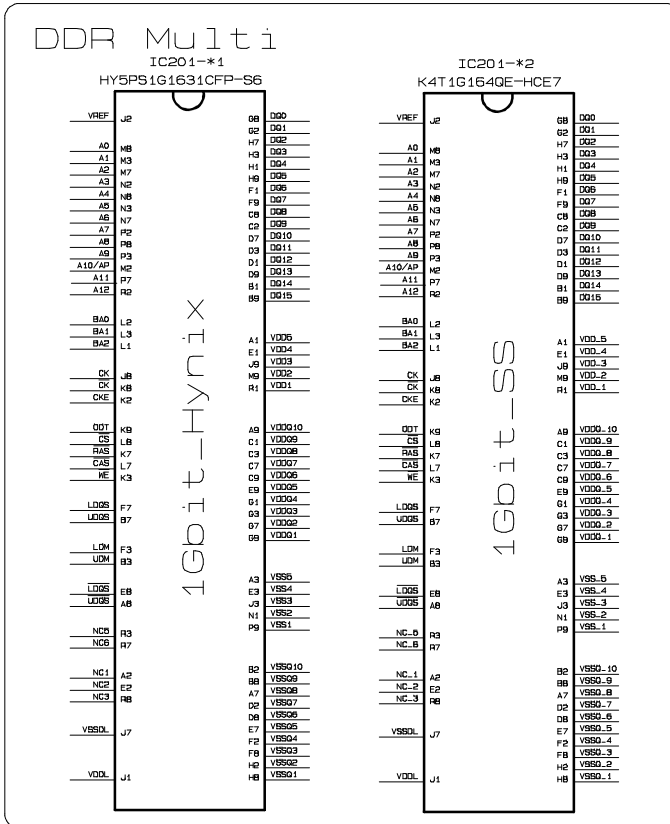
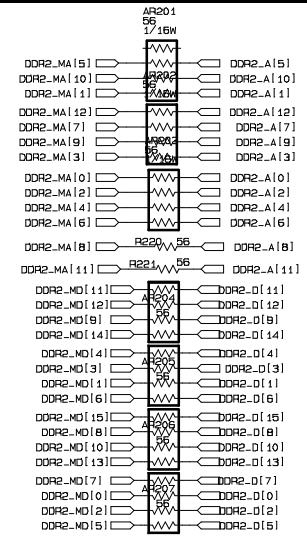
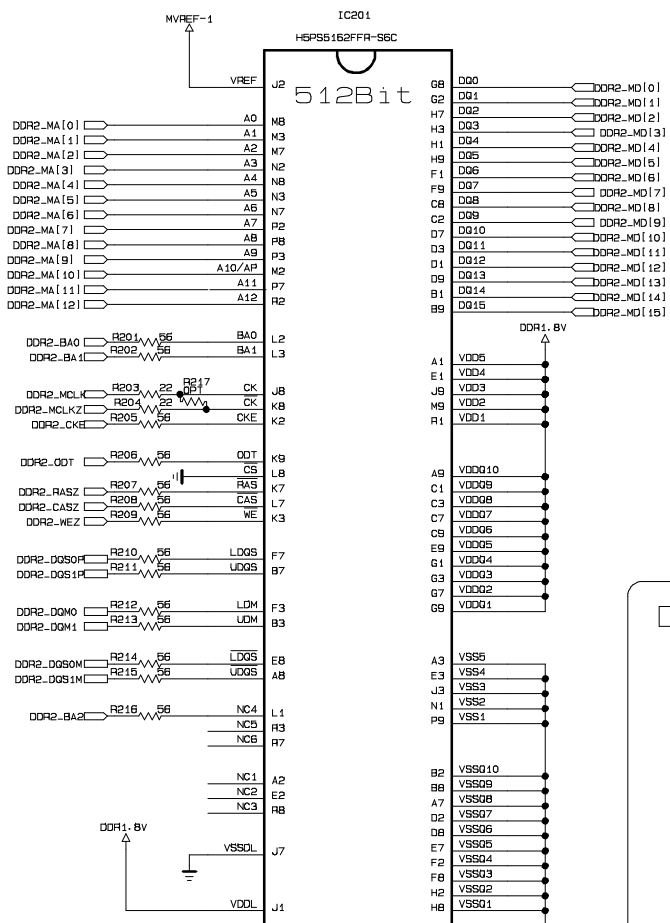

THE SYMBOL MARK OF THIS SCHEMATIC DIAGRAM INCORPORATES SPECIAL FEATURES IMPORTANT FOR PROTECTION FROM X-RADIATION. FILRE AND ELECTRICAL SHOCK HAZARDS, WHEN SERVICING IF IS ESSENTIAL THAT ONLY MANUFACTURES SPECIFIED PARTS BE USED FOR THE CRITICAL COMPONENTS IN THE SYMBOL MARK OF THE SCHEMATIC.

SECRET	LG ELECTRONICS	MODEL	DATE
LGElectronics		BLOCK	SHEET

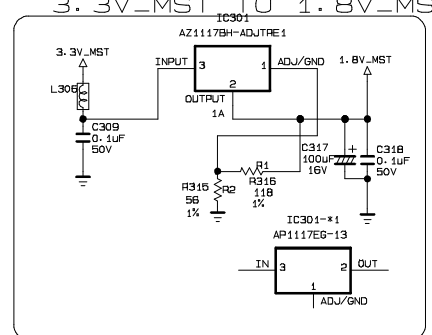
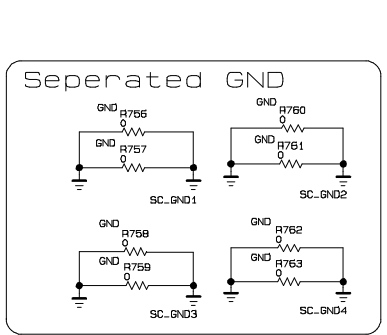
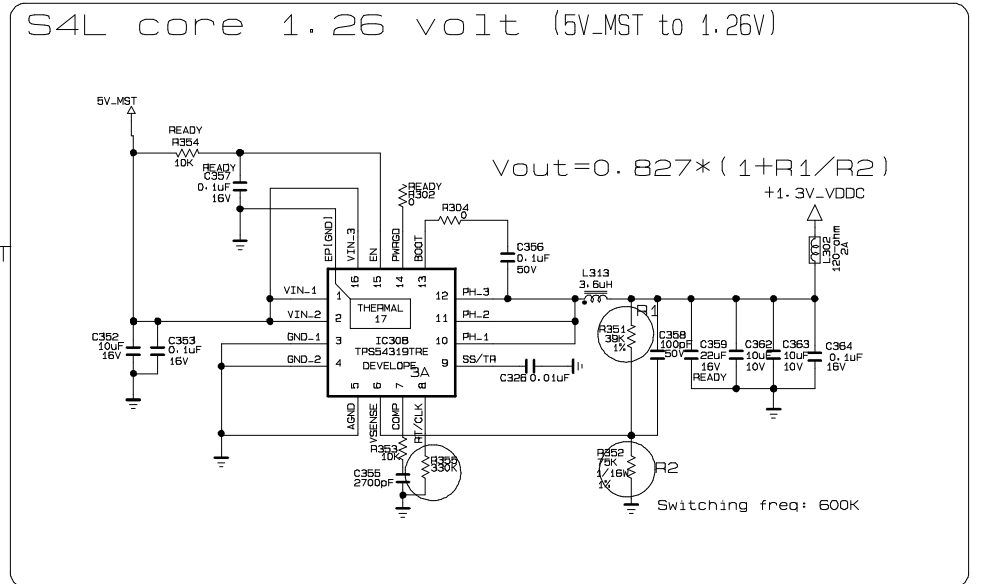
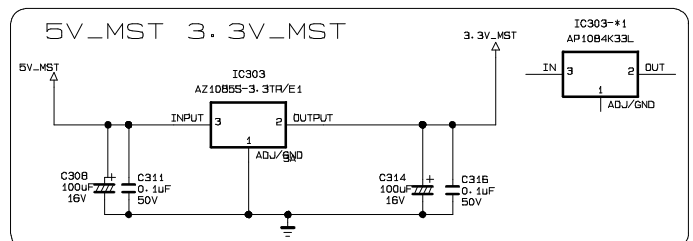
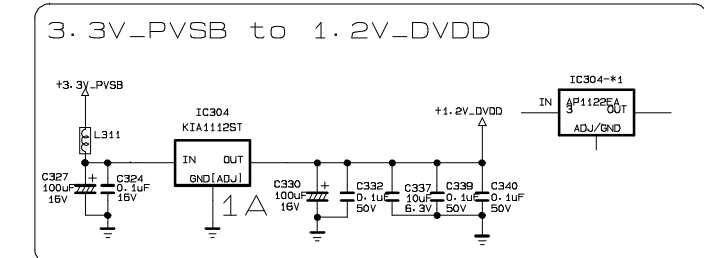
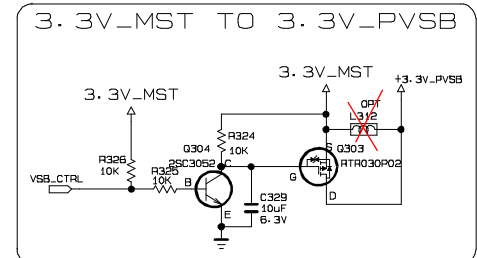
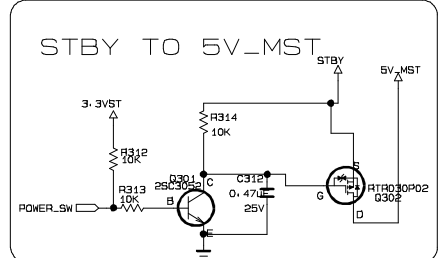
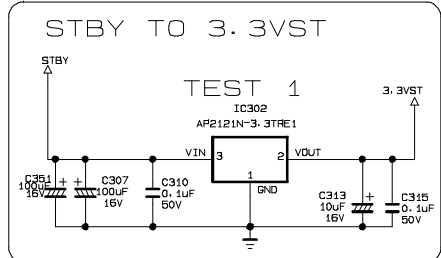
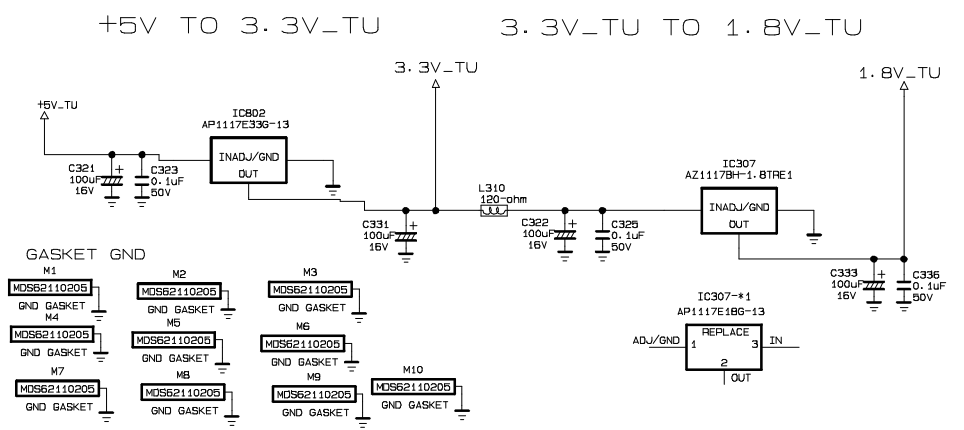
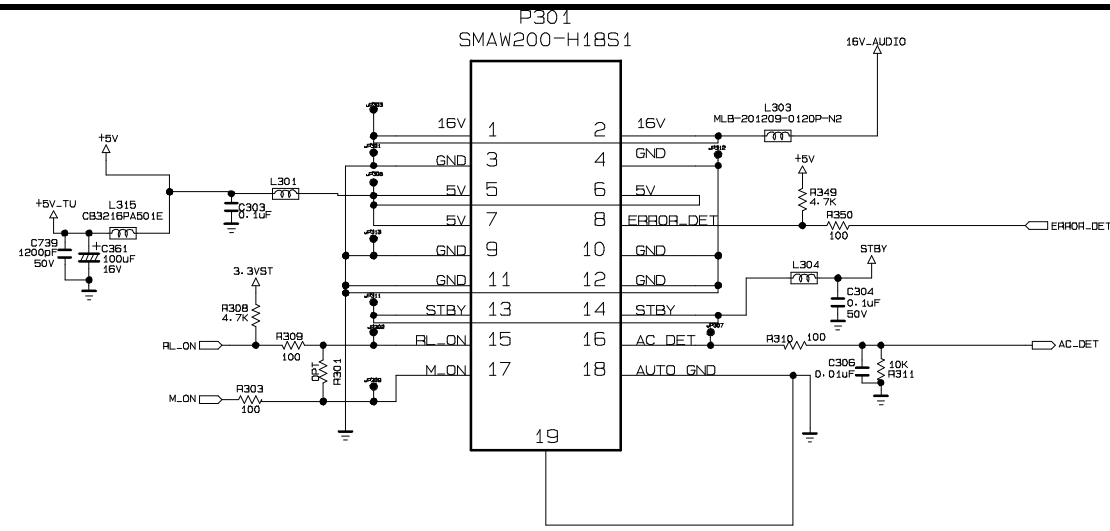

THE  $\Delta$  SYMBOL MARK OF THIS SCHEMATIC DIAGRAM INCORPORATES SPECIAL FEATURES IMPORTANT FOR PROTECTION FROM X-RADIATION. FILRE AND ELECTRICAL SHOCK HAZARDS, WHEN SERVICING IF IS ESSENTIAL THAT ONLY MANUFACTURES SPECIFIED PARTS BE USED FOR THE CRITICAL COMPONENTS IN THE  $\Delta$  SYMBOL MARK OF THE SCHEMATIC.

SECRET  
LGElectronics



MODEL	DATE
BLOCK	SHEET

I2C Address : C2

Analog Supply Max Current(+3.3V/Operating) : 250mA  
 (+1.8V/Operating) : 75mA  
 Digital Supply Max Current (+1.8V/Operating) : 75mA

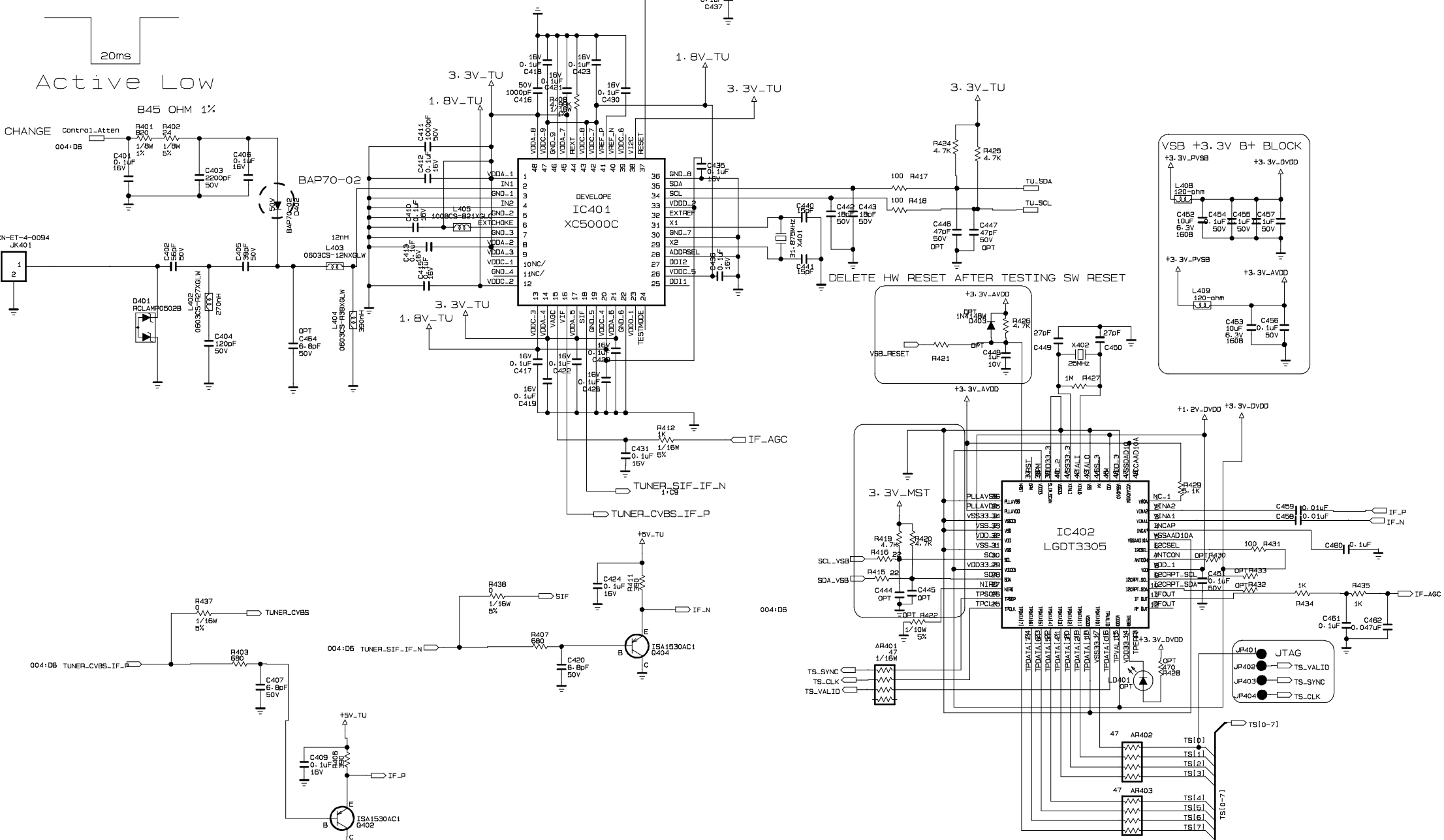

THE SYMBOL MARK OF THIS SCHEMATIC DIAGRAM INCORPORATES SPECIAL FEATURES IMPORTANT FOR PROTECTION FROM X-RADIATION. FILTRE AND ELECTRICAL SHOCK HAZARDS. WHEN SERVICING IF IS ESSENTIAL THAT ONLY MANUFACTURES SPECIFIED PARTS BE USED FOR THE CRITICAL COMPONENTS IN THE SYMBOL MARK OF THE SCHEMATIC.

SECRET	LG ELECTRONICS
LGElectronics	

MODEL	DATE
BLOCK	SHEET

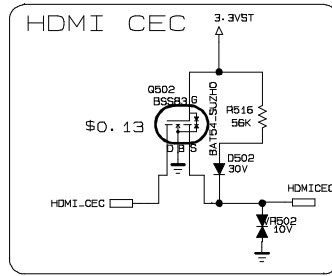
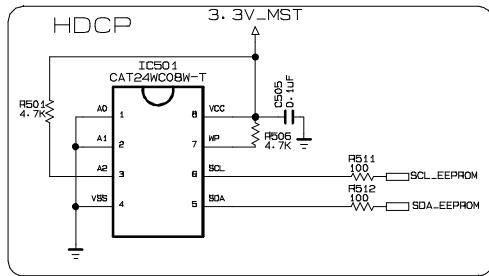

REAR HDMI

HDMI 2

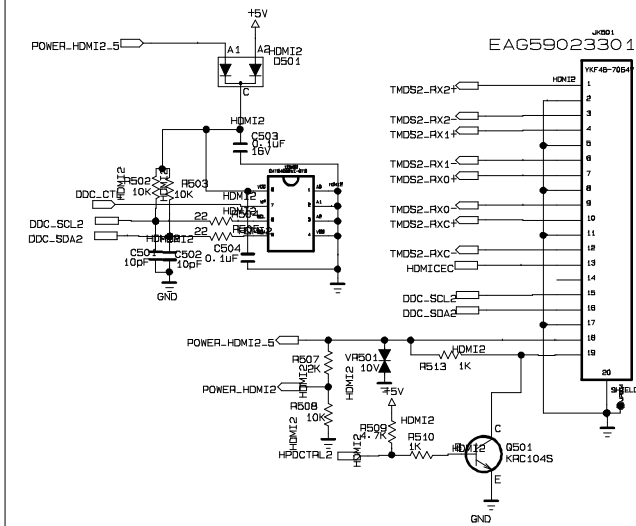

HDMI 1

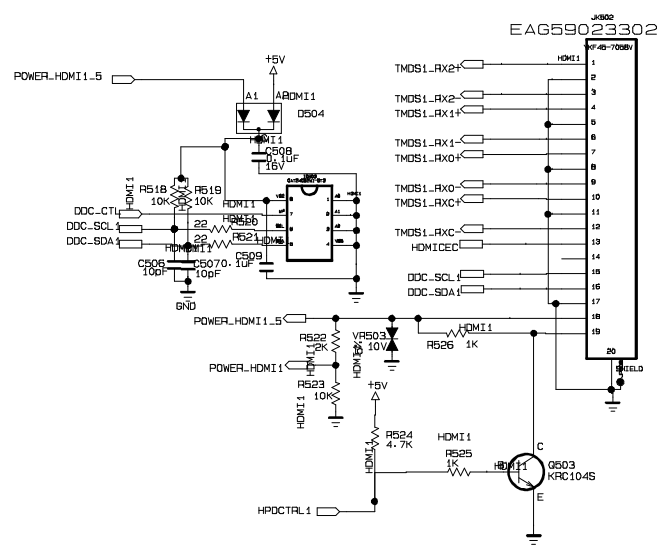

SIDE HDMI

HDMI 3

EAG62611201

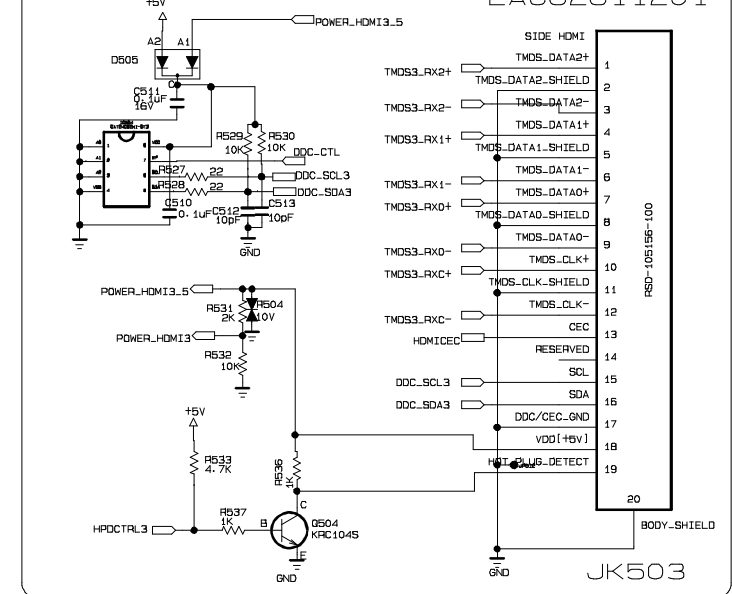

THE SYMBOL MARK OF THIS SCHEMATIC DIAGRAM INCORPORATES SPECIAL FEATURES IMPORTANT FOR PROTECTION FROM X-RADIATION. FILRE AND ELECTRICAL SHOCK HAZARDS, WHEN SERVICING IF IS ESSENTIAL THAT ONLY MANUFACTURES SPECIFIED PARTS BE USED FOR THE CRITICAL COMPONENTS IN THE SYMBOL MARK OF THE SCHEMATIC.

SECRET	LG ELECTRONICS
LGElectronics	

MODEL		DATE	
BLOCK		SHEET	/



# HD LVDS

# HD LVDS

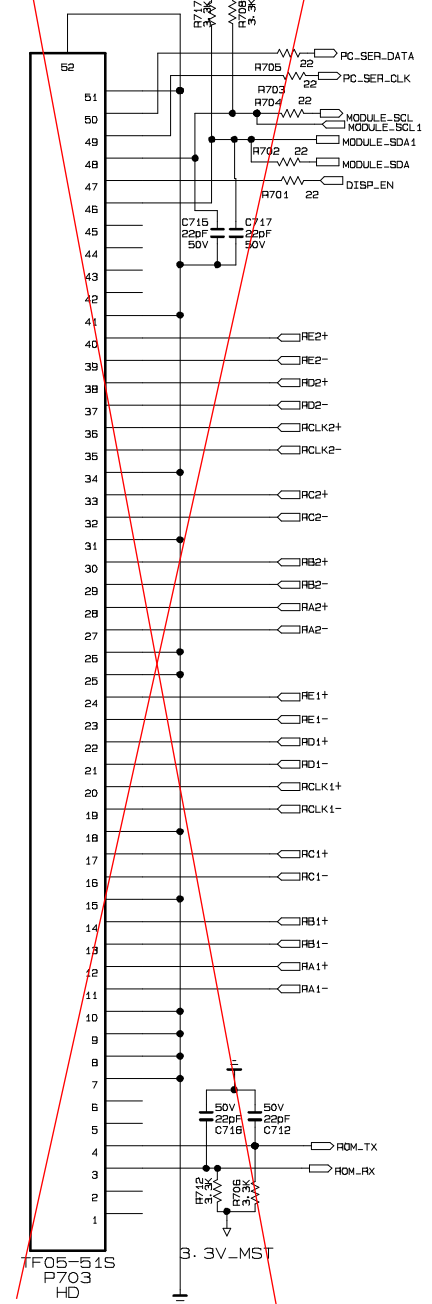
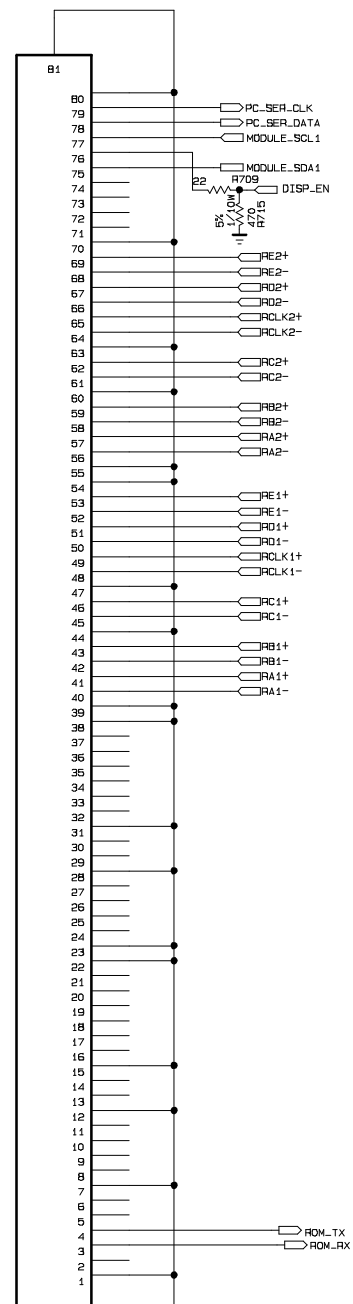

# REAR USB

EAG59068701

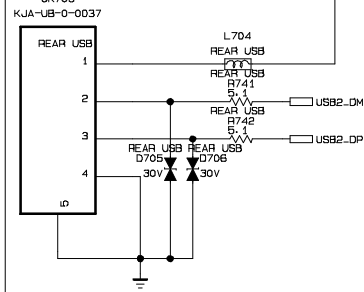

# RS232

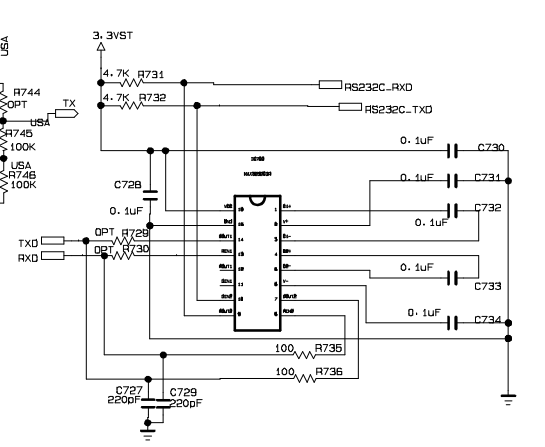
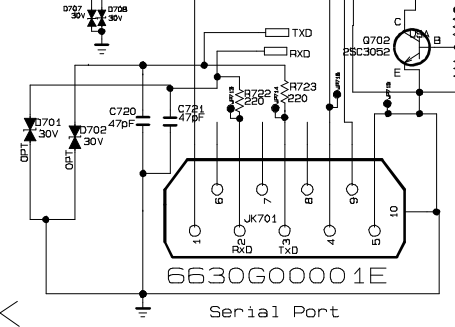

# USA IR JACK

EAG60841801

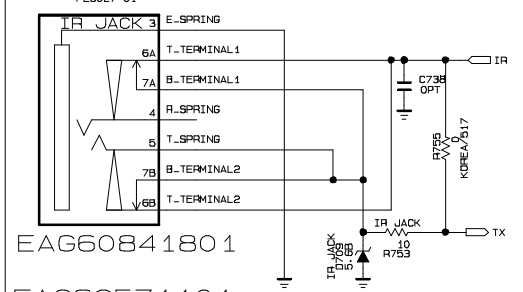

EAG62571101

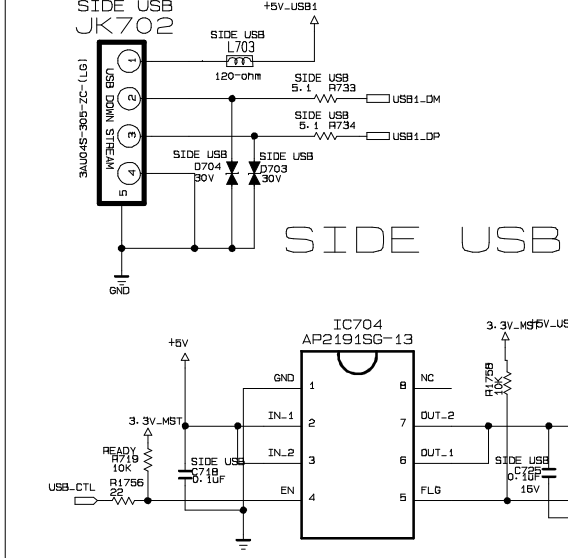

# SIDE USB

# IR & CTRL & BUZZ

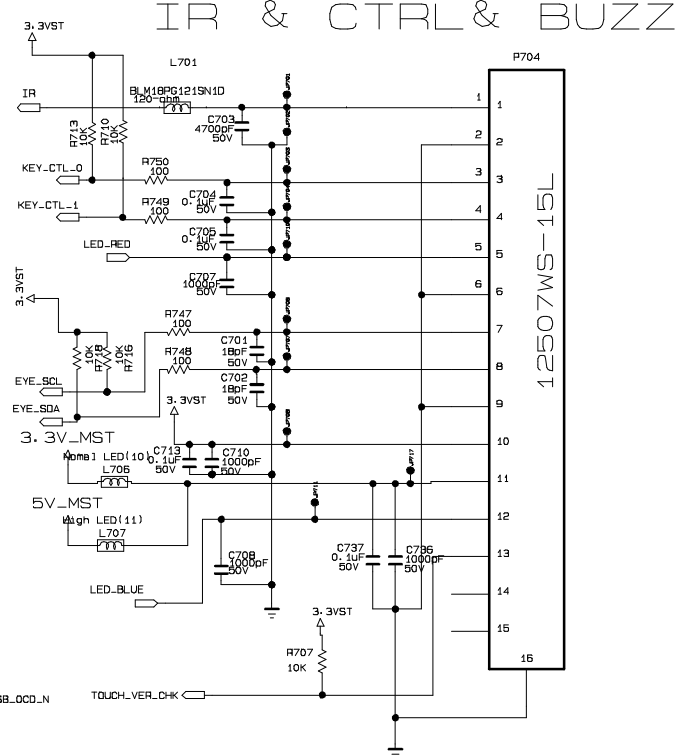

104059-8017  
 THE SYMBOL MARK OF THIS SCHEMATIC DIAGRAM INCORPORATES SPECIAL FEATURES IMPORTANT FOR PROTECTION FROM X-RADIATION. FILTRE AND ELECTRICAL SHOCK HAZARDS, WHEN SERVICING IF IS ESSENTIAL THAT ONLY MANUFACTURES SPECIFIED PARTS BE USED FOR THE CRITICAL COMPONENTS IN THE SYMBOL MARK OF THE SCHEMATIC.

SECRET	
LGElectronics	

MODEL	DATE
BLOCK	SHEET

# COMPLEX

# COMPONENT 1

COMPLEX JACK  
EAG6100780 1

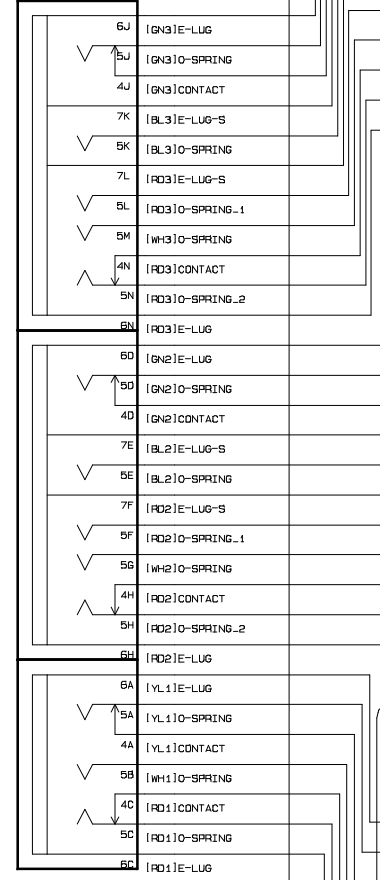
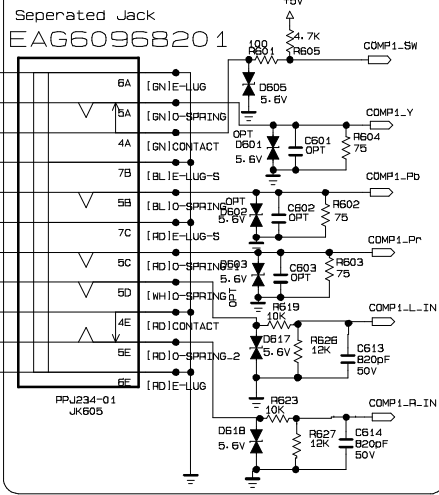

THE  $\Delta$  SYMBOL MARK OF THIS SCHEMATIC DIAGRAM INCORPORATES SPECIAL FEATURES IMPORTANT FOR PROTECTION FROM X-RADIATION, FILRE AND ELECTRICAL SHOCK HAZARDS, WHEN SERVICING IF IS ESSENTIAL THAT ONLY MANUFACTURES SPECIFIED PARTS BE USED FOR THE CRITICAL COMPONENTS IN THE  $\Delta$  SYMBOL MARK OF THE SCHEMATIC.

# SIDE AV

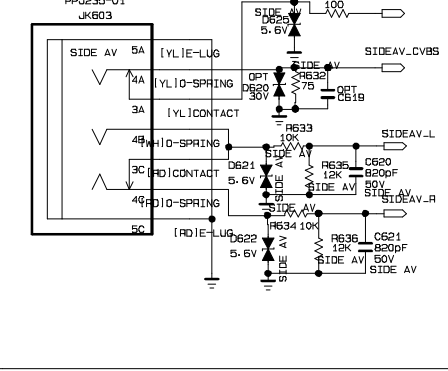

# COMPONENT 2

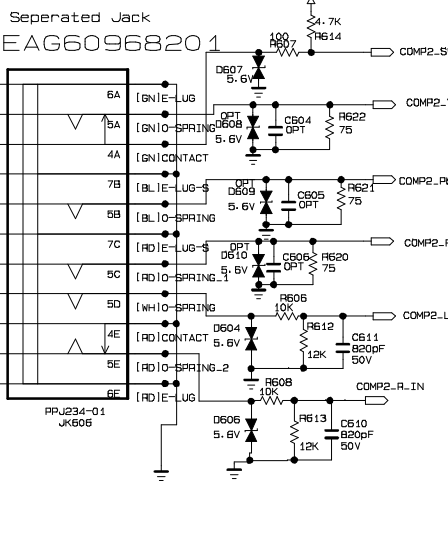

# REAR AV

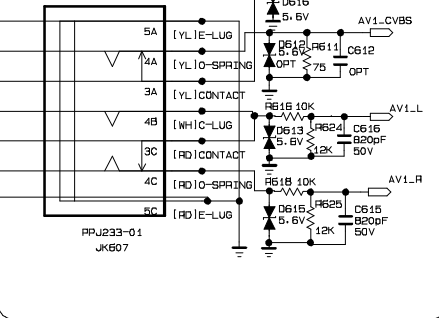

# RGB & PHONE

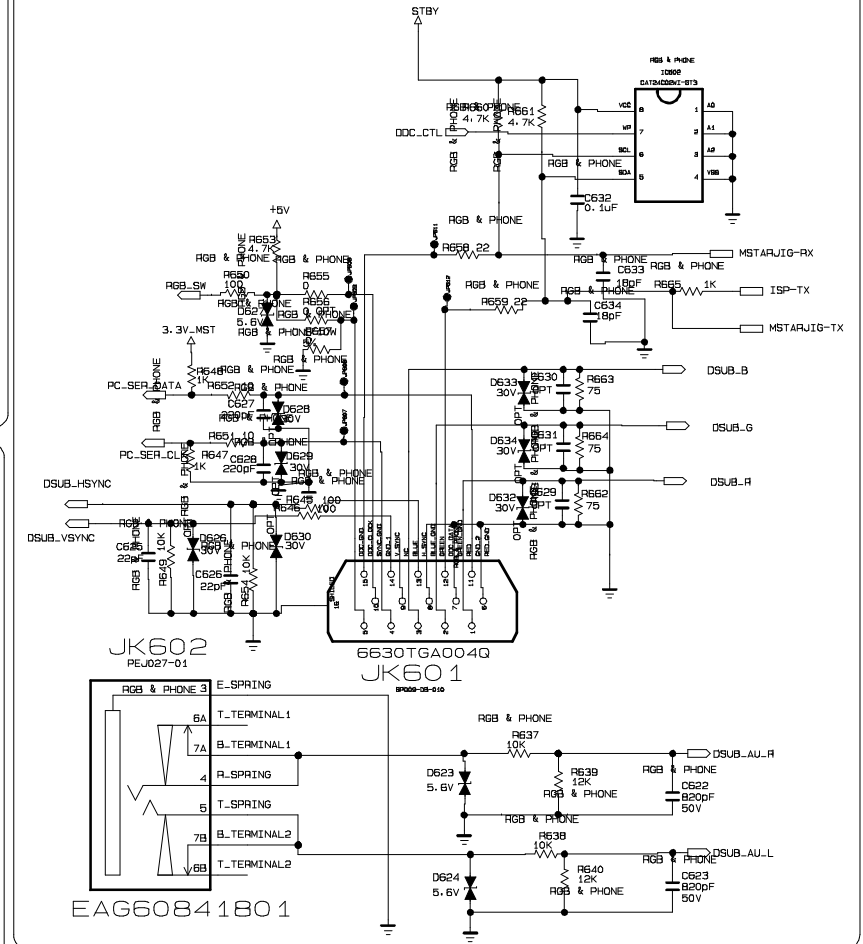

# SPDIF OPTIC JACK

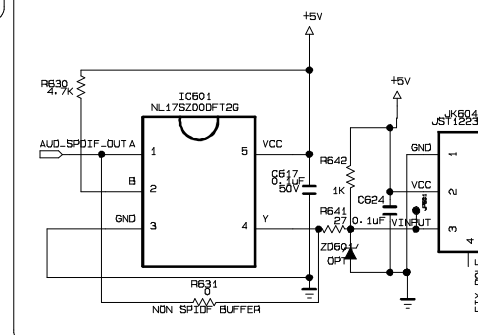

# I2C JIG [4P]

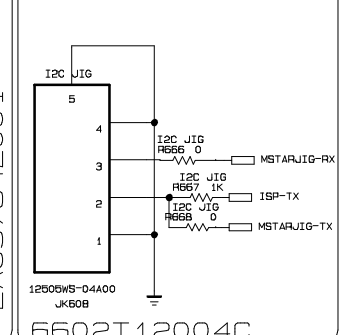

**SECRET**  
LGElectronics

**LG ELECTRONICS**

MODEL		DATE	
BLOCK		SHEET	/

# Digital Audio AMP

This parts are Located on AVSS area.

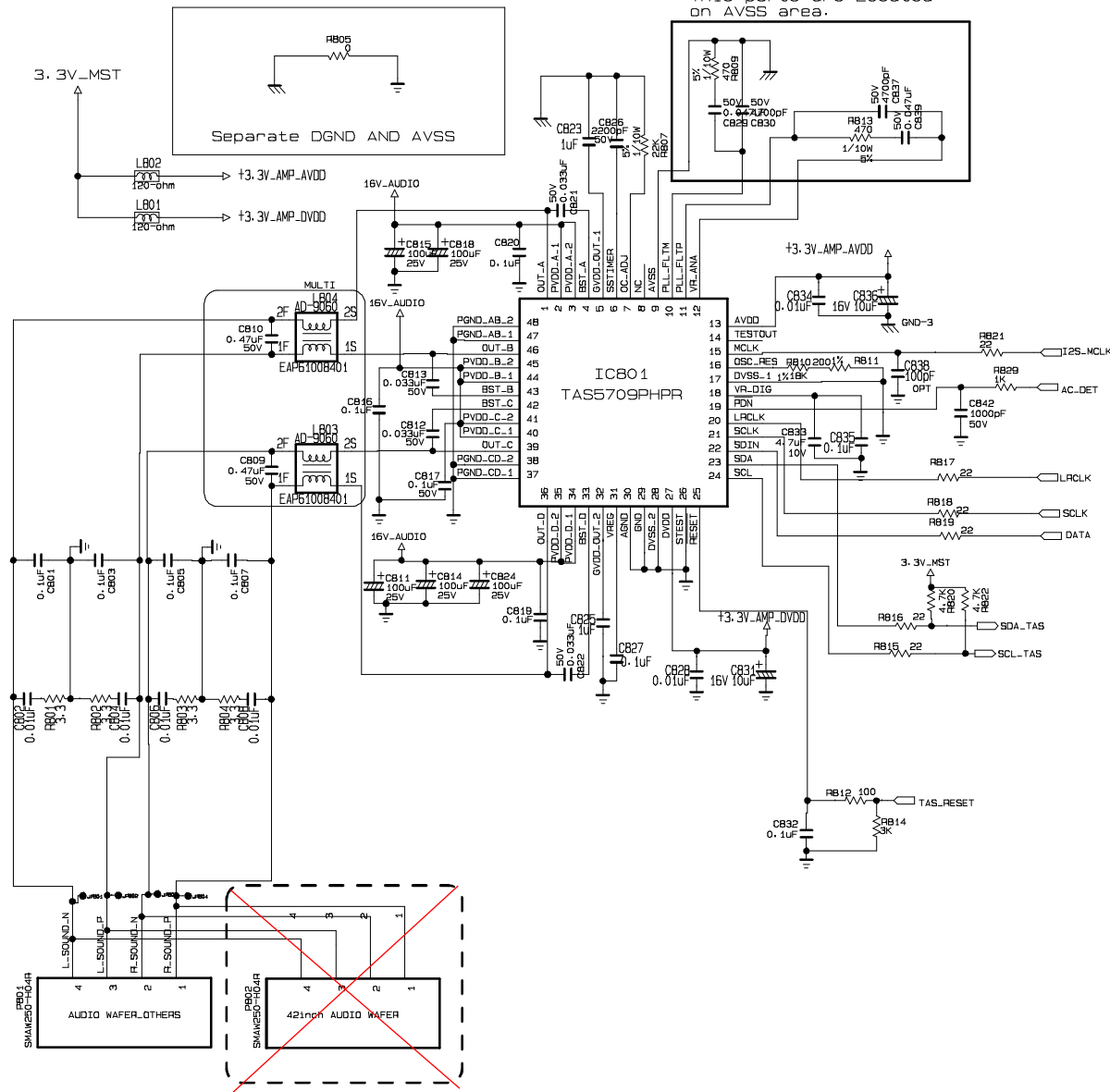

THE SYMBOL MARK OF THIS SCHEMATIC DIAGRAM INCORPORATES SPECIAL FEATURES IMPORTANT FOR PROTECTION FROM X-RADIATION. FILRE AND ELECTRICAL SHOCK HAZARDS. WHEN SERVICING IF IS ESSENTIAL THAT ONLY MANUFACTURES SPECIFIED PARTS BE USED FOR THE CRITICAL COMPONENTS IN THE SYMBOL MARK OF THE SCHEMATIC.

SECRET	LG ELECTRONICS
LGElectronics	

MODEL		DATE	
BLOCK		SHEET	/