

# 5. Service Modes, Error Codes, and Fault Finding

**Index of this chapter:**

- 5.1 Test Points
- 5.2 Service Modes
- 5.3 Problems and Solving Tips Related to CSM
- 5.4 Service Tools
- 5.5 Error Codes
- 5.6 The Blinking LED Procedure
- 5.7 Software Downloading
- 5.8 Fault Finding and Repair Tips

- Timer / Sleep timer.
- Child / parental lock.
- Blue mute.
- Hotel / hospital mode.
- Auto shut off (when no "IDENT" video signal is received for 15 minutes).
- Skipping of non-favourite presets / channels.
- Auto-storage of personal presets.
- Auto user menu time-out.
- Auto Volume Levelling (AVL).

## 5.1 Test Points

This chassis is equipped with test points in the service printing. In the schematics, test points are identified with a rectangle box around Fxxx or lxxx. These test points are specifically mentioned in the service manual as "half moons" with a dot in the centre.

The chassis is equipped with test points (Fxxx) printed on the circuit board assemblies. As most signals are digital, it will be almost impossible to measure waveforms with a standard oscilloscope. Therefore, waveforms are not given in this manual.

Perform measurements under the following conditions:

- Television set in Service Default Alignment Mode.
- Video input: Colour bar signal.
- Audio input: 3 kHz left channel, 1 kHz right channel.

## 5.2 Service Modes

Service Default mode (SDM) and Service Alignment Mode (SAM) offer several features for the service technician, while the Customer Service Mode (CSM) and the Digital Customer Service Mode (DCSM, only for TVs with digital reception module) are used for communication between the call centre and the customer.

This chassis offers the option of using the IAP Tool (In Application Programming), a hardware interface between a computer and the TV chassis, for software uploading to the TV set. See also paragraph "Service Tools: IAP Tool".

### 5.2.1 Service Default Mode (SDM)

**Purpose**

- To create a predefined setting for measurements to be made.
- To override software protections.
- To start the "Blinking LED Procedure".
- To inspect the error buffer.
- To check the life timer.

**Specifications**

**Table 5-1 SDM default settings**

Region	Freq. (MHz)	Default system
Europe, AP-PAL/Multi	475.25	PAL B/G
NAFTA, AP-NTSC, LATAM	61.25 (ch. 3)	NTSC M

- All picture settings at 50% (brightness, colour contrast, hue).
- Bass, treble and balance at 50%; volume at 25%.
- All service-unfriendly modes (if present) are disabled. The service unfriendly modes are:

**How to Enter**

To enter SDM, use one of the following methods:

- Press the following key sequence on the remote control transmitter: "062596" directly followed by the MENU button (do not allow the OSD display to time out between entries while keying the sequence).
- Short the SDM contact to mass (see Figure "SDM Service contact") on the TV board and apply AC Power. Remove the short after start-up.

**Caution:** Entering SDM by shorting the "Service" contact to mass will override the software protections. Do this only for a short period. **When doing this, the service-technician must know exactly what he is doing, as it could damage the television set.**

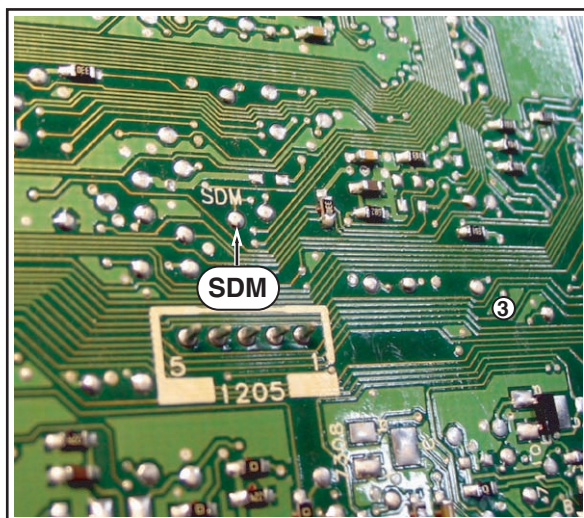

G\_16350\_050.eps  
060406

**Figure 5-1 SDM Service contact (for SDM: short to mass)**

After entering SDM, the following screen is visible, with SDM in the upper right corner of the screen to indicate that the television is in Service Default Mode.

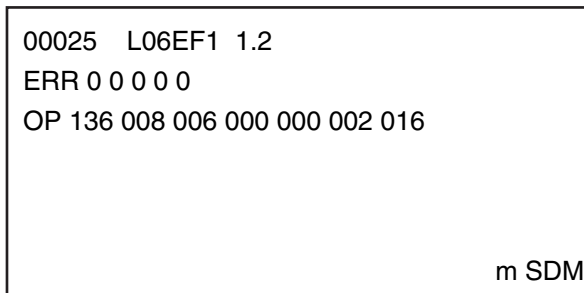

G\_16350\_051.eps  
060406

**Figure 5-2 SDM menu (example)**

**How to Navigate**

When you press the MENU button on the remote control, the set will switch on the normal user menu in the SDM mode.

**How to Exit**

Switch the set to STANDBY by pressing the POWER button on the remote control transmitter.

If you turn the television set off by removing the mains (i.e., unplugging the television) or by using the POWER button on the TV set, the television set will remain in SDM when mains is re-applied, and the error buffer is not cleared.

**5.2.2 Service Alignment Mode (SAM)****Purpose**

- To change option settings.
- To display / clear the error code buffer.
- To perform alignments.

**Specifications**

- Operation hours counter (maximum five digits displayed).
- Software version, Error codes, and Option settings display.
- Error buffer clearing.
- Option settings.
- Software alignments (Tuner, RGB Align, Geometry, and Audio).
- NVM Editor.
- IAP Mode switching (Compair mode not implemented).

**How to Enter**

Press the following key sequence on the remote control transmitter: "062596" directly followed by the OSD/STATUS/INFO button (do not allow the OSD display to time out between entries while keying the sequence).

After entering SAM, the following screen is visible, with SAM in the upper right corner of the screen to indicate that the television is in Service Alignment Mode.

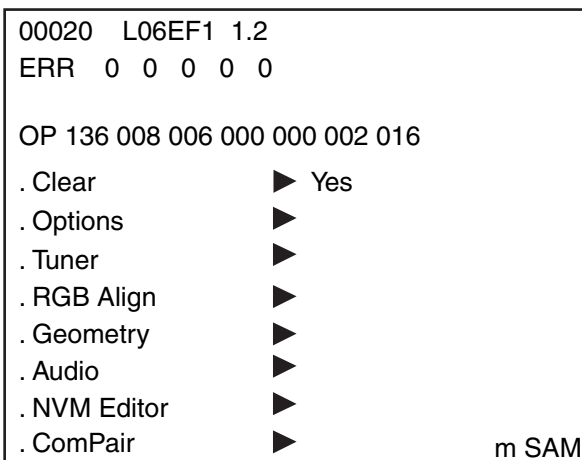

G\_16350\_052.eps  
060406

Figure 5-3 SAM menu (example)

**Menu Explanation**

1. **LLLLL**. This represents the run timer. The run timer counts normal operation hours (including "on/off" switching), but does not count stand-by hours.
2. **AAA.BC-X.Y**. This is the software identification of the Main/Scaler microprocessor:
  - **AAA.B** = the chassis name.
  - **B** = the display indicator.
  - **C** = the region: E= Europe, A= Asia Pacific, U= NAFTA, L= LATAM, G= Global.

- **X**= the Main software version number (updated with a major change that is incompatible with previous versions).
  - **Y**= the sub software version number (updated with a minor change that is compatible with previous versions).
3. **Error Buffer (ERR)**. Shows all errors detected since the last time the buffer was erased. Five errors possible.
  4. **Option Bytes (OP)**. Shows all option settings. See "Options" in the Alignments section for a detailed description. Seven codes are available.
  5. **See Note below** (about other menu items).
  6. **SAM**. Indication of the Service Alignment Mode.

**Note:** The other menu items (**Clear, Options, Tuner, RGB Align, Geometry, Audio, NVM Editor, and Compair**) are explained at the end of this chapter, together with the menu structure. See: "SAM Menu structure".

**How to Navigate**

- In SAM, select menu items with the CURSOR UP/DOWN keys on the remote control transmitter. The selected item will be highlighted. When not all menu items fit on the screen, use the CURSOR UP/DOWN keys to display the next / previous menu items.
- With the CURSOR LEFT/RIGHT keys, it is possible to:
  - Activate the selected menu item.
  - Change the value of the selected menu item.
  - Activate the selected submenu.
- In SAM, when you press the MENU button twice, the set will switch to the normal user menus (with the SAM mode still active in the background). To return to the SAM menu press the MENU button again.
- When you press the MENU key in while in a submenu, you will return to the previous menu.

**How to store SAM settings**

To store the settings changed in SAM mode, leave the top level SAM menu by using the POWER button on the remote control transmitter or the television set.

**How to exit**

Switch the set to STANDBY by pressing the POWER button on the remote control transmitter or on the television set.

**5.2.3 Customer Service Mode (CSM)****Purpose**

The Customer Service Mode shows error codes and information on the TV's operation settings. The call centre can instruct the customer (by telephone) to enter CSM in order to identify the status of the set. This helps the call centre to diagnose problems and failures in the TV set before making a service call.

The CSM is a read-only mode; therefore, modifications are not possible in this mode.

**How to Enter**

To enter CSM, press the following key sequence on the remote control transmitter: "123654" (do not allow the OSD display to time out between entries while keying the sequence).

Upon entering the Customer Service Mode, the following screen will appear:

```

1 00025 L06EF1 1.2
2 CODES 0 0 0 0 0
3 OP 136 008 006 000 000 002 016
4
5 CTN
6
7 PAL
8 DUAL I
9 CO 50 CL 50 BR 50 HU 0
0 AVL Off
                                m CSM

```

G\_16350\_053.eps  
060406

Figure 5-4 CSM menu (example)

#### Menu Explanation

1. Indication of the decimal value of the operation hours counter, Main/Scaler software version (see "Service Alignment Mode" for an explanation), and service mode (CSM= Customer Service Mode).
2. Displays the last five errors detected in the error code buffer.
3. Displays the option bytes.
4. Reserved.
5. Displays the type number version of the set (option).
6. Reserved.
7. Displays the detected Colour system (e.g. PAL/NTSC).
8. Displays the detected Audio (e.g. stereo/mono).
9. Displays the picture setting information.
10. Displays the sound setting information.

#### How to Exit

To exit CSM, use one of the following methods:

- Press the MENU, STATUS (or EXIT/INFO/[i+]), or POWER button on the remote control transmitter.
- Press the POWER button on the television set.

## 5.3 Problems and Solving Tips Related to CSM

### 5.3.1 Picture Problems

**Note:** The problems described below are all related to the TV settings. The procedures used to change the value (or status) of the different settings are described.

#### Picture Too Dark or Too Bright

*If:*

- The picture improves when you enter the Customer Service Mode,

*Then:*

1. Press the MENU button on the remote control transmitter. This brings up the normal user menu; the PICTURE sub menu is highlighted.
2. Press the CURSOR RIGHT key to enter the PICTURE sub menu.
3. Press the CURSOR UP/DOWN keys to increase or decrease the BRIGHTNESS value.
4. Press the MENU button on the remote control transmitter twice to exit the user menu.
5. The new PERSONAL preference values are automatically stored.

#### White Line(s) Around Picture Elements and Text

*If:*

There are white lines around picture elements and text,

*Then:*

1. Press the MENU button on the remote control transmitter. This brings up the normal user menu (PICTURE is highlighted).
2. Use the CURSOR DOWN key to select SHARPNESS.
3. Press the CURSOR RIGHT key to enter the SHARPNESS adjustment mode.
4. Press the CURSOR UP/DOWN keys to increase or decrease the SHARPNESS value.
5. Press the MENU button on the remote control transmitter twice to exit the user menu.
6. The new PERSONAL preference value is automatically stored.

#### Snowy Picture

Check the following:

- Antenna not connected. Connect the antenna.
- No antenna signal or bad antenna signal. Connect a proper antenna signal.
- The tuner is faulty (in this case line 2, the Error Buffer line, will contain error number 9). Check the tuner and replace/repair the tuner if necessary.

#### Black and White Picture

*If:*

- The picture is (nearly) in black and white when it should be in colour,

*Then:*

1. Press the MENU button on the remote control transmitter. This brings up the normal user menu (PICTURE is highlighted).
2. Press the CURSOR RIGHT key to enter the PICTURE sub menu.
3. Use the CURSOR DOWN key to select COLOUR.
4. Press the CURSOR UP/DOWN keys to increase the COLOUR value.
5. Press the MENU button on the remote control transmitter twice to exit the user menu.
6. The new PERSONAL preference value is automatically stored.

## 5.4 Service Tools

### 5.4.1 IAP Tool: system requirements

#### PC

The PC used for IAP should meet the following criteria:

- Parallel Port;
- Windows XP Operating System;
- 60 MB free disk space.

### 5.4.2 IAP Tool: use

#### Introduction

The IAP Tool (In Application Programming) is a service tool for uploading software to a TV set (see Figure "IAP Interface"). In order to use IAP, the following items should be available:

- **PC;**
- **TV set,** to be put in the IAP mode (only when it is connected to the PC via the IAP interface);
- **IAP interface,** (parallel to I<sup>2</sup>C, for the connection between a PC and the TV set);
- **IAP Trident EXSDK software package,** software will be available via your national service organisation.

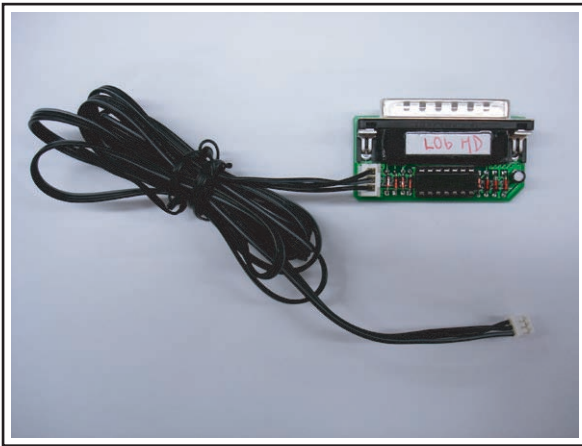

G\_16350\_062.eps  
060406

Figure 5-5 IAP interface

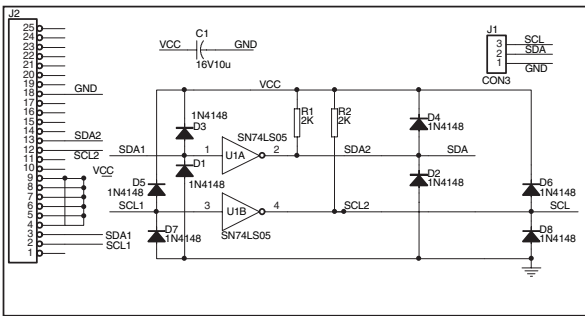

G\_16350\_063.eps  
060406

Figure 5-6 IAP interface circuit diagram

**Installing the IAP software on a PC**

When all the items mentioned above are present, install the software on a PC as follows:

- Extract the Trident EXSDK package (EXSDK.zip) into C:\Trident\Bin.
- The IAPWriter6.exe file is now inside the Bin folder.

**Programming the Flash IC**

The pre-requisite for flashing the software is that the Flash IC should have a bootloader (this means that there is already software on the TV set). To start the flashing, do as follows:

- Turn on the TV set, enter SAM mode > IAP. The TV is now in the IAP mode.
- Connect the PC to the TV via the Parallel-to-I<sup>2</sup>C card (IAP Interface).
- Double-click on C:\Trident\Bin\IAPWriter6.exe in order to launch the IAP writer. The main interface will appear.
- Check that these parameters are set correctly:

```

DEVICE          STM29W400DT
MPU Start Address 080000
MPU End Address  0FBFFF
Buffer Start Address 000000
Buffer End Address 07FFFF
    
```

**Note:** The device depends on the Flash IC used.

- Select File > Load, and select the .bin file to be programmed to the Flash IC.
- Select File Type "Binary".
- Select "Write Device".

**Note:** If there are no errors reported, the programming is successful.

**Note:** Sometimes, an error message may appear. Please try a few times if this happens.

**How to Order**

**Note:** If you encounter any problems, contact your local support desk.

**5.5 Error Codes**

**5.5.1 Introduction**

The error code buffer contains all detected errors since the last time the buffer was erased. The buffer is written from left to right, new errors are logged at the left side, and all other errors shift one position to the right.

When an error has occurred, the error is added to the list of errors, provided the list is not full or the error is a protection error.

When an error occurs and the error buffer is full, then the new error is not added, and the error buffer stays intact (history is maintained), except when the error is a protection error.

To prevent that an occasional error stays in the list forever, the error is removed from the list after 50+ operation hours.

When multiple errors occur (errors occurred within a short time span), there is a high probability that there is some relation between them.

**5.5.2 How to Read the Error Buffer**

Use one of the following methods:

- On screen via the SAM (only if you have a picture).  
Examples:
  - 0 0 0 0: No errors detected
  - 6 0 0 0: Error code 6 is the last and only detected error
  - 9 6 0 0: Error code 6 was first detected and error code 9 is the last detected error
- Via the blinking LED procedure (when you have no picture). See next paragraph.
- Via IAP.

**5.5.3 How to Clear the Error Buffer**

Use **one** of the following methods:

- By activation of the "CLEAR ERRORS" command in the SAM menu.
- With a normal RC, key in sequence "MUTE" followed by "062599" and "OK".
- If the content of the error buffer has not changed for 50+ hours, it resets automatically.

**5.5.4 Error Codes**

The function of error codes is to indicate failures in the TV set. In principle a unique error code is available for every:

- I<sup>2</sup>C device error.
- I<sup>2</sup>C bus error (for every bus containing two or more I<sup>2</sup>C devices).
- Protection error (e.g. +8V protection or Horizontal protection).
- Error not related to an I<sup>2</sup>C device, but of importance (e.g. BC-loop, RAM error).

Table 5-2 Error Table

Error	Description
0	0 = No error
2	High beam (BCI) protection
3	Vertical guard protection
4	POR bit / +8 V protection
7	Black current loop instability protection
8	General I <sup>2</sup> C error Microprocessor (M30620FCNGP)
9	I <sup>2</sup> C error while communicating with the PLL tuner (UV1316E)
10	I <sup>2</sup> C error while communicating with the EEPROM (NVM at uP, M24C64)
11	I <sup>2</sup> C error while communicating with the IF demodulator (TDA9886T/V4)
12	I <sup>2</sup> C error while communicating with the Trident (SVPEX42)
13	I <sup>2</sup> C error while communicating with the HOP (TDA9332H/N3)
14	I <sup>2</sup> C error while communicating with the HDMI (SIL9011 CLU)
15	I <sup>2</sup> C error while communicating with the Audio Demodulator (MSP3411G)
16	I <sup>2</sup> C error while communicating with the ADC RGB (AD9985KST-110)
19	I <sup>2</sup> C error while communicating with the SDRAM IC (K4D263238F)

**Service Tips:**

- In case of non-intermittent faults, clear the error buffer before you begin the repair. This to ensure that old error codes are no longer present. Before clearing the buffer, write down the content, as this history can give you significant information.
- If possible, check the entire contents of the error buffer. In some situations, an error code is only the result of another error code and not the actual cause (e.g., a fault in the protection detection circuitry can also lead to a protection).

**5.6 The Blinking LED Procedure****5.6.1 Introduction**

Via this procedure, you can make the contents of the error buffer visible via the front LED. This is especially useful for fault finding, when there is no picture.

When the SDM is activated, the front LED will show (by blinking) the contents of the error-buffer. Error-codes > 10 are shown as follows:

1. A long blink of 750 ms (which is an indication of the decimal digit),
2. A pause of 1500 ms,
3. "n" short blinks (where "n" = 1 - 9),
4. When all the error-codes are displayed, the sequence finishes with a LED blink of 3000 ms,
5. The sequence starts again.

**Example:** Error 12 9 6 0 0.

After activation of the SDM, the front LED will show:

1. 1 long blink of 750 ms (which is an indication of the decimal digit) followed by a pause of 1500 ms,
2. 2 short blinks of 250 ms, followed by a pause of 3000 ms,
3. 9 short blinks of 250 ms, followed by a pause of 3000 ms,
4. 6 short blinks of 250 ms, followed by a pause of 3000 ms,
5. 1 long blink of 3000 ms to finish the sequence,
6. The sequence starts again.

**5.6.2 How to Activate**

Use one of the following methods:

- Activate the SDM (only by shorting the soldering pad indicated in Figure "SDM Service contact" on the first page of this chapter to mass). The blinking front LED will show the entire contents of the error buffer (this works in "normal operation" mode and in "protection" mode). In order to avoid confusion with RC5 signal reception blinking, this LED blinking procedure is terminated when an RC5 command is received.
- Transmit the commands "MUTE", "06250x", and "OK" with a normal RC (where "x" is the position in the error buffer that has to be displayed). With x= 1, the last detected error is shown, x= 2 the second last error, etc.... When x= 0, all errors are shown.
- "DIAGNOSE X" with the DST (where "x" is the position in the error buffer that has to be displayed). With x= 1, the last detected error is shown, x= 2 the second last error, etc.... When x= 0, all errors are shown.

**Note:** It can take some seconds before the blinking LED starts.

**5.7 Software Downloading**

In this chassis, you can **upgrade** the software via the IAP Tool (In Application Programming). You can find more information on this in the paragraph "Service Tools" in this chapter.

**5.8 Fault Finding and Repair Tips****Notes:**

- It is assumed that the components are mounted correctly with correct values and no bad solder joints.
- Before any fault finding actions, check if the correct options are set.

**5.8.1 NVM Editor**

In some cases, it can be handy if one directly can change the NVM contents. This can be done with the "NVM Editor" in SAM mode. In the next table, the default NVM values are given.

Table 5-3 NVM default values

Item	Address (dec)	Default values (hex)		Default values (dec)	
		29PT9521/12	32PW9551/12	29PT9521/12	32PW9551/12
EW (EW Width)	19	15	1A	21	26
PW (EW Parabola Width)	20	19	19	25	25
HS (Horizontal Shift)	21	20	20	32	32
HP (Horizontal Parallelogram)	22	07	07	07	07
HB (Horizontal Bow)	23	07	07	07	07
UCP (EW Upper Corner Parabola)	24	20	20	32	32
LCP (EW Lower Corner Parabola)	25	20	20	32	32
TC (EW Trapezium)	26	1D	1D	29	29
VS (Vertical Slope)	27	27	27	39	39
VA (Vertical Amplitude)	28	20	20	32	32
SC (S-Correction)	29	15	15	21	21
VSH (Vertical Shift)	30	20	20	32	32
VX (Vertical Zoom)	31	19	19	25	25
VSL (Vertical Scroll)	32	20	20	32	32
HOP EW EHT Compensation	33	20	20	32	32
BLOR (Black Level Offset - Red)	34	08	08	08	08
BLOG (Black Level Offset - Green)	35	08	08	08	08
AGC (AGC Takeover)	36	0E	0E	14	14
OIF (IF-PLL Offset)	37	20	20	32	32
AGC10	38	01	01	01	01
H60 (60 Hz Horizontal Shift)	39	00	00	00	00
60 Hz Vertical Amplitude	42	04	04	04	04
YD & CL	43	04	07	04	07
RGB Brightness	46	28	28	40	40
NVM_TABLE_VERSION	60	64	64	100	100
OPTION_TABLE_VERSION	61	3C	3C	60	60
TXT Brightness	64	14	14	20	20
V60 offset (60Hz Vertical Amplitude)	66	04	04	04	04
CRYSTALALIGN	208	00	00	00	00
VIDEO PP	264	23	23	35	35
Last Colour	265	36	36	54	54
Last Contrast	266	64	64	100	100
Last Sharpness	267	05	05	05	05
Last Hue	268	32	32	50	50
Last Colour Temp	269	00	00	00	00
White-D Cool Red	294	00	00	00	00
White-D Cool Green	295	00	00	00	00
White-D Cool Blue	296	04	04	04	04
White-D Normal Red	297	25	25	37	37
White-D Normal Green	298	20	20	32	32
White-D Normal Blue	299	28	28	40	40
White-D Warm Red	300	08	08	08	08
White-D Warm Green	301	00	00	00	00
White-D Warm Blue	302	ED	ED	237	237
Audio Last Smart	342	03	03	03	03
Last Volume	343	23	23	35	35
Last Balance	344	0A	0A	10	10
Last Treble	345	00	00	00	00
Last Bass	346	00	00	00	00

**Note:**

- When aligning a TV set, it is convenient to start with the default settings, and then to change them, if necessary, to customized values.
- If you suspect a defective TV set is programmed with the wrong settings or options, try to restore the set to its default settings or set the options to their virgin mode (the latter can also be done via the NVM Editor in the SAM menu, see chapter 8 and the table Option codes).

If the remote control of a TV set is defective or missing, and you can not enter the CSM or SAM menu, it is always possible to return the TV to its virgin mode by simultaneously pressing the Volume+ and Volume- keys on the Top Control/Side I/O panel of the TV set.

## 5.8.2 SAM Menu Structure

The SAM Menu structure of the L06.1E AA is different from that of the ES1. Some of the menu items that were in the main menu of the ES1 are now in the submenu. The following table shows the structure of the SAM menu of the L06.1E AA.

Table 5-4 SAM menu structure

SAM Main Menu	SAM Submenu level 1	SAM Submenu level 2	Example of SAM Submenu values / settings	Explanation of menu items	
Clear			Yes	<b>Clear.</b> Erases the contents of the error buffer. Select the CLEAR menu item and press the CURSOR RIGHT key. The content of the error buffer is cleared.	
Options	OP1			<b>Options.</b> Used to set the option bits. See "Options" in the Alignments section for a detailed description.	
	OP2				
	OP3				
	OP4				
	OP5				
	OP6				
	OP7				
Tuner	IFPLL			<b>Tuner.</b> Used to align the tuner. See "Tuner" in the Alignments section for a detailed description.	
	AGC				
RGB Align	AKB		Off / On	<b>RGB Align &gt; White Tone.</b> Used to align the white tone. See "RGB Align > White Tone" in the Alignments section for a detailed description.	
	White Tone	Cool			
		Normal			
		Warm			
		BlackL Offset R			
		BlackL Offset G			
CL		7			
Geometry	Horizontal	HP	8	<b>Geometry.</b> Used to align the Geometry. See "Geometry" in the Alignments section for a detailed description.	
		HB	9		
		HSH	33		
		EWV	23		
		EWP	26		
		EWT	31		
		UCP	41		
		LCP	34		
	Vertical	SBL			<b>Note:</b> If the TV set is switched to 50 Hz/double lines (i.e. not Pixel Plus/100 Hz) only "VS" is shown in the menu.
		VS	42		
		VSH	26		
		VAM	25		
		VSC	21		
Audio	AF-M		250	<b>Audio.</b> No audio alignment is necessary for this television set.	
	A2-T		400		
	AT		2		
NVM Editor	ADR		0x0001 1	<b>NVM Editor.</b> Can be used to change the NVM data in the television set.	
	VAL		0x0000 0		
	Store				
Compair	Compair			<b>ComPair.</b> In other TV sets, this menu item can be used to switch the television to "In System Programming" (ISP) mode, for software uploading via ComPair. In the L061E AA, however, a different system is used: IAP. <b>Caution:</b> When this mode is selected without IAP connected, the TV will be blocked. Remove the AC power to reset the TV.	
	IAP			<b>IAP.</b> This tool is used instead of Compair (Compair is not implemented in this TV set).	